

MB12

Geleidingssysteem
Guidance system
Führungssystem
Boîte de guidage

MB-SERIE

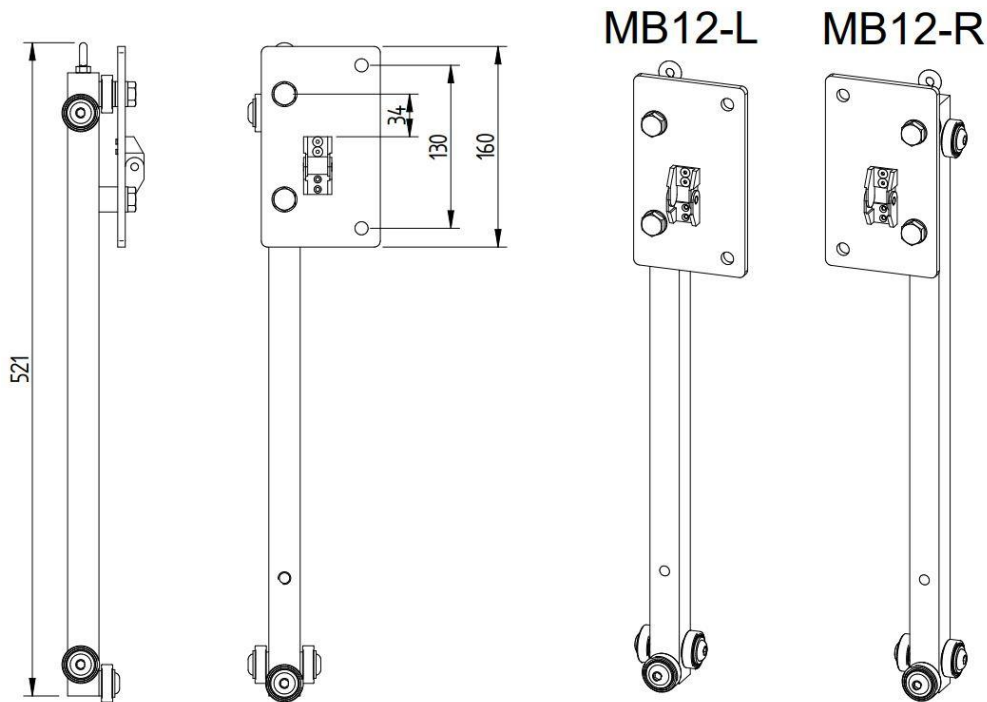

Specifications

TYPE		MB12-L	MB12-R
Mmax	[Nm]	250	250
m	[kg]	2	2
T-serie	[-]	TW2-L/TW2-D	TW2-R

OPTIONS	SPECIFICATIONS
Energy Chain	Available per meter
Counterweight	12 kg
Guiding Rail	4500 mm

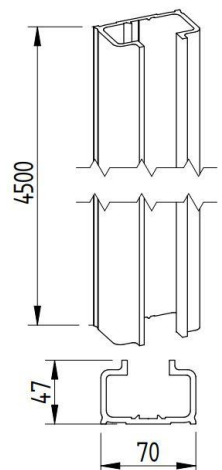
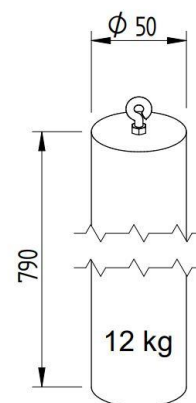
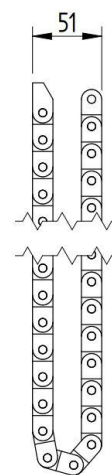

Options